

Hydraulic Rotary Rig

# SR-45

## ADV



**soilmec**   
Drilling and Foundation Equipment

# SR-45 ADV Hydraulic Rotary Rig

## LDP APPLICATIONS - Crowd System with Cylinder

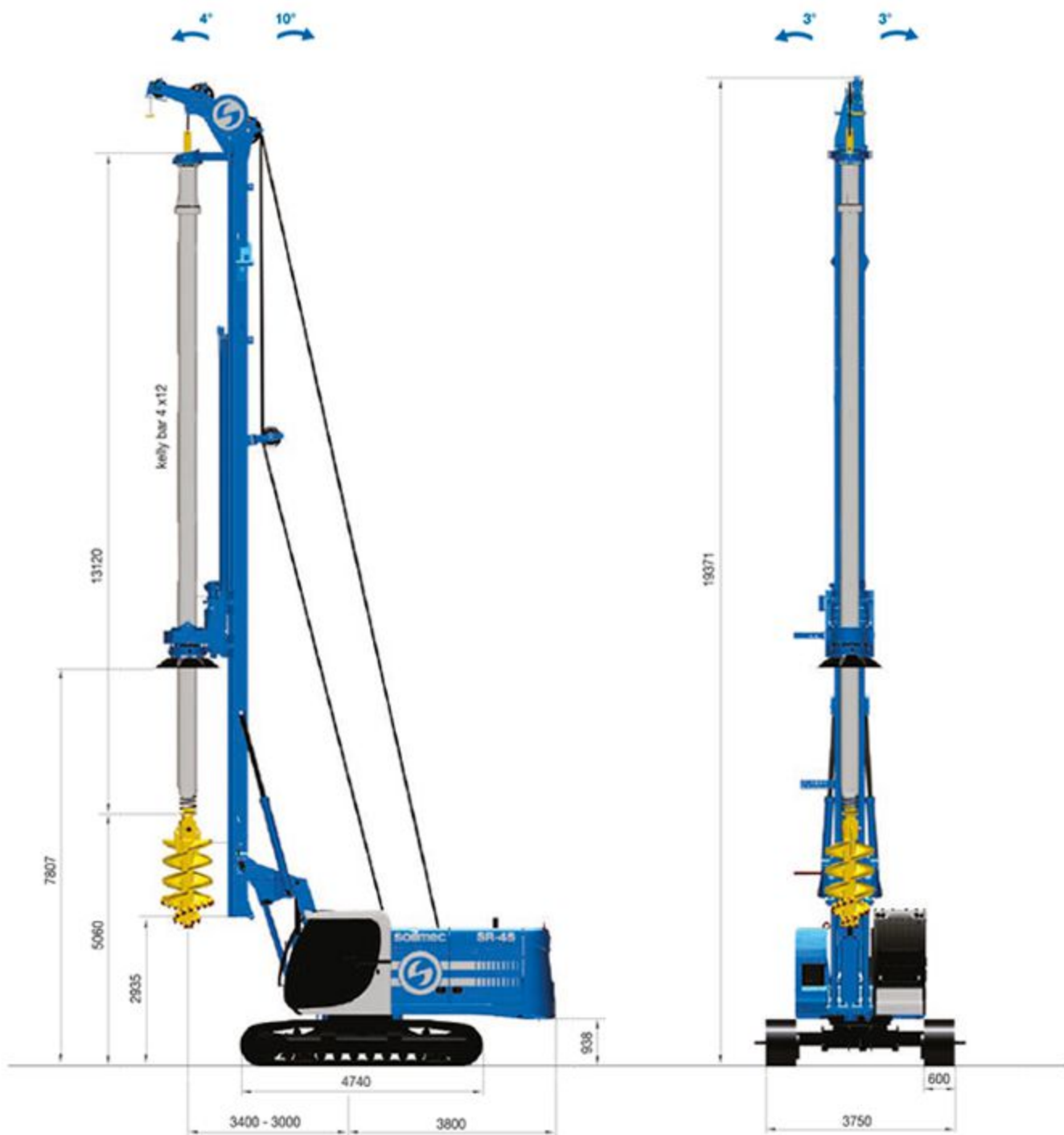

### LDP - Large Diameter Piles - CCS version

Operating weight w/o kelly	36700 kg	80909 lb
Max pile diameter (along mast)	1500 mm	59.06 in
Max pile diameter tool below mast	3000 mm	118 in
Max pile depth - friction kelly	58,5 - 65** m	192 - 213** ft
Max pile depth - locking kelly	47,5 - 50,5* m	156 - 166* ft

\* c/w non self-mounting 4x14 kelly bar \*\* c/w non self-mounting 5x14 kelly bar

### LDP - Large Diameter Piles - CCS Rathlers

Max pile depth - locking kelly	61,5 m	201.77 ft
--------------------------------	--------	-----------

# SR-45 ADV Hydraulic Rotary Rig

## LDP APPLICATIONS - Crowd System with Winch



### LDP - Large Diameter Piles - WCS version

Operating weight w/o kelly	38200 kg	84216 lb
Max pile diameter (along mast)	1300 mm	51.18 in
Max pile diameter w/o lower mast section, tool below mast	3000 mm	118 in
Max pile depth - friction kelly	65,5 m	215 ft
Max pile depth - locking kelly	51,8 m	170 ft

## SR-45 ADV Hydraulic Rotary Rig

### ROTARY TABLE

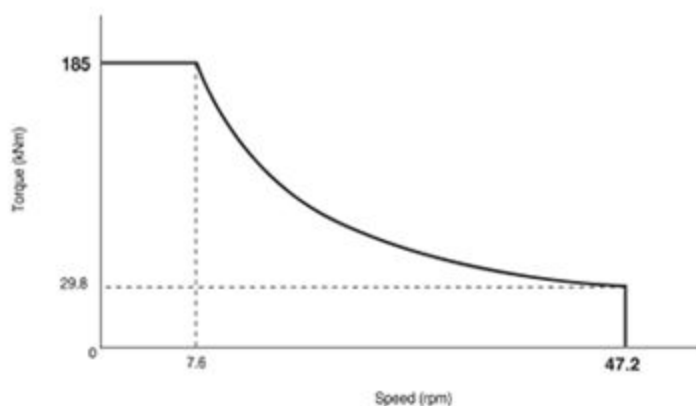
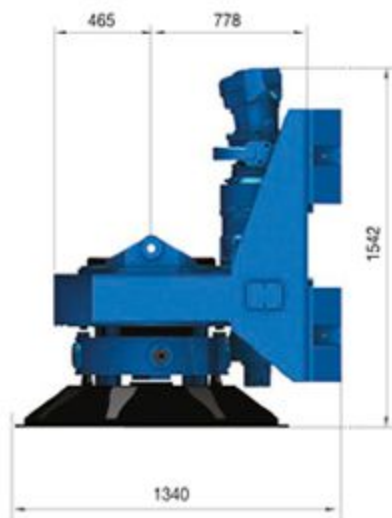
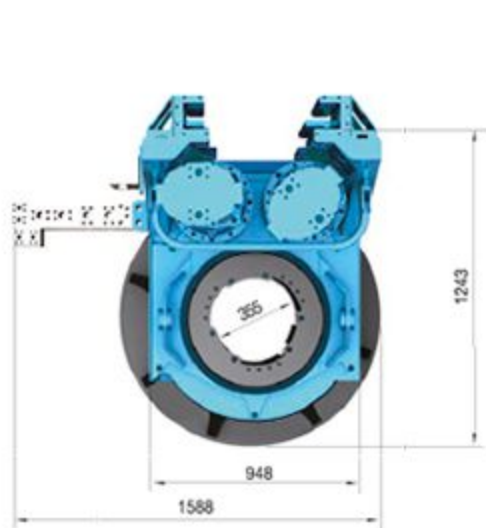

#### Rotary drive

- Max torque (intermittent)
- Rated torque
- Speed of rotation (max)
- Spin-off speed
- Weight

#### Single gear version

185 kNm  
161 kNm  
47 rpm  
146 rpm  
2850 kg

#### Single gear version

136447 lb\*ft  
118746 lb\*ft  
47 rpm  
146 rpm  
6283 lb

## SR-45 ADV Hydraulic Rotary Rig

Safety equipment compulsory for EC marking  
On request whenever EC marking is not needed

- Catwalks for cab 600 mm (2 ft) wide
- Handrails kit
- Acoustic alarm for rotation and translation
- Radio remote control for tramping on ramp
- Video-camera set with 4 cameras included
- Rearview mirrors
- Led lights
- Oil discharge conveying system
- Load cell for service winch

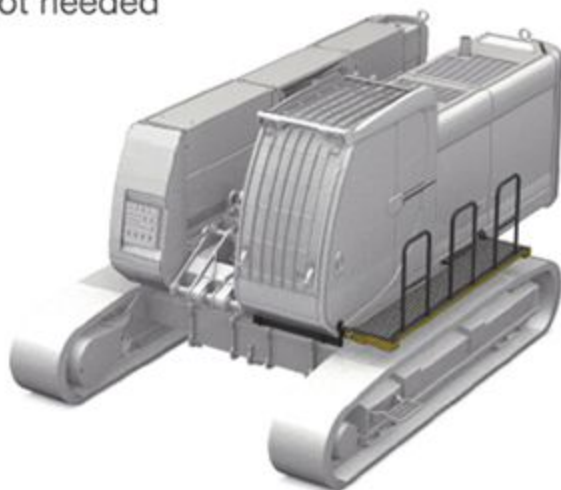



<b>CCS - Cylinder crowd system</b>		
- Crowd force pull (down/up)	140 / 207 kN	31500 / 46500 lbf
- Stroke	5100 mm	201 in
- Speed (down/up)	17,4 m/min	57 ft/min
- Fast speed (down/up)	18,8 m/min	62 ft/min
<b>WCS - Winch crowd system</b>		
- Crowd force pull (down/up)	240 / 240 kN	54000 / 54000 lbf
- Stroke	14500 mm	740 in
- Speed (down/up)	28 m/min	92 ft/min
- Fast speed (down/up)	28 m/min	92 ft/min
<b>Main winch</b>	<b>controlled descent</b>	<i>controlled descent</i>
- Line pull (1st layer)	165 kN	37100 lbf
- Rope diameter	24 mm	1.26 in/482.28 ft
- Line speed (max.)	78 m/min	256 ft/min
<b>Auxiliary winch</b>	<b>controlled descent</b>	<i>controlled descent</i>
- Line pull (1st layer)	65 kN	29225 lbf
- Rope diameter	18 mm	0.87 in
- Line speed (max.)	81 m/min	230 ft/min
<b>Engine</b>	<b>CUMMINS QSB 6.7</b>	<i>CUMMINS QSB 6.7</i>
- Rated output	201 kW @ 2000 rpm	269 HP @ 2000 rpm
- Engine conforms to Exhaust emission Standard	<b>EU stage IV, US EPA Tier 4f</b>	<i>EU stage IV, US EPA Tier 4f</i>
- Diesel tank capacity	380 l	100 US gal
<b>Hydraulic system</b>		
- Flow rates (main circuits)	2x 214 l/min	2x 57 US gal/min
- Flow rates (auxiliary circuits)	120 l/min	26.4 US gal/min
- Hydraulic oil tank capacity	450 l	119 US gal
<b>Undercarriage</b>	<b>variable gauge, telescoping side frames</b>	<i>variable gauge, telescoping sides frames</i>
- Overall width of crawlers retracted/extended	2550 / 3750 mm	100 / 147 in
- Width of triple grouser track shoes	600 mm	24 in
- Overall length of crawlers	4740 mm	187 in
- Traction force effective/nominal	386 kN	68800 lbf
- Travel speed	2 km/h	1.2 mph
<b>Mast inclination (Backward/ Forward/Lateral)</b>	<b>10/4/3°</b>	<i>10/4/3°</i>

## STANDARD EQUIPMENT

- Main and auxiliary winch controlled descent type with special grooving
- Hoist limit switch on main and service rope
- Swivel for main rope
- Service rope parking point
- GSM/GPRS/GPS modem kit
- DMS system electronic monitoring and visualization system
- Mast inclination measurement on X/Y axes (digital/analog display)
- Automatic vertical mast alignment
- Depth measuring device
- Rotary speed measuring device
- Variable gauge undercarriage
- Wider triple grouser track shoes
- Transport securing lugs on crawler units
- Oscillator attachment brackets
- Lower foldable mast element
- Cardan joint
- Flange for casing driving
- Kelly swivel
- Kelly guide
- Kit for fastening kelly bar during transport
- On board lighting set
- On board tool set
- Electric refuelling pump
- High comfortable H-Cab 1050 mm (3,4 ft) wide
- Protective roof grate (FOPS compliant)
- Sliding door
- Adjustable console with sliding support for DMS 12" touch screen
- Engine and Diesel particulate diagnostic panel 3 color warning light
- Ergonomic seat with air suspension, fully-adjustable positioning and lumbar support
- Heat and Air Conditioning control unit
- Courtesy lights in the cab
- Radio and CD player

## OPTIONAL EQUIPMENT

- Diesel Engine with EU Stage III A - US EPA Tier 3 motorization
- Additional Counterweight 1 ton
- Fiberglass canopies
- Lubricator pump kit for rotary pads cradle
- Flange for bucket opening
- Hydraulic prearrangement for casing oscillator
- Mast extension for special configuration
- Automatic hydraulic kit for upper mast folding
- Limit switch for rope winding and winches
- Free fall service winch
- Double roller auger cleaner
- Star auger cleaner
- Prearrangement for VTH-1
- Automatic mast raising kit
- Kit for transport w/o counterweight

# SR-45 ADV Hydraulic Rotary Rig

## KELLY DRILLING SYSTEM



Drilling Depths	Kelly Dimensions section x m	Depth		Weight		CCS SYSTEM		WCS SYSTEM	
		m	ft	ton	ton (US)	H		H	
						m	ft	m	ft
3 parts	BL HD 3 x 8	21,0	68,9	3,1	3,1	7,9	25,9	8,8	28,9
	BL HD 3 x 10,5	28,5	93,5	3,8	3,9	6,3	20,7	6,3	20,7
	BL HD 3 x 12	33,1	108,6	4,3	4,4	4,8	15,7	4,8	15,7
4 parts	BL HD 4 x 9	31,8	104,3	3,4	3,5	7,8	25,6	7,8	25,6
	BL HD 4 x 10,5	38,1	125,0	3,9	4,0	6,3	20,7	6,3	20,7
	BL HD 4 x 11,5	40,6	132,2	4,7	4,8	5,3	17,4	5,3	17,4
	BL HD 4 x 12	44,1	144,7	5,0	5,1	4,9	16,0	4,9	16,0
	BL HD 4 x 13	48,0	157,5	5,3	5,4	3,9	12,8	3,9	12,8
	BL HD * 4 x 14	51,8	170,0	6,7	6,8	2,9	9,5	2,9	9,5
5 parts	FR HD 4 x 9	32,1	105,3	3,4	3,5	7,9	25,9	7,9	25,9
	FR HD 4 x 12	44,5	146,0	4,3	4,4	5,0	16,4	5,0	16,4
	FR HD 5 x 12	54,5	178,8	5,2	5,3	4,9	16,1	4,9	16,1
	FR HD ** 5 x 13,5	61,5	201,8	7,6	7,7	5,5	18	5,5	18,0
	FR HD * 5 x 14	65,5	214,9	7,8	7,9	3,0	9,8	3,0	9,8

\* Non self-mountable kelly bar

\*\* Rathole dedicated kelly bar

# SR-45 ADV Hydraulic Rotary Rig

## TRANSPORT, DIMENSIONS AND WEIGHTS

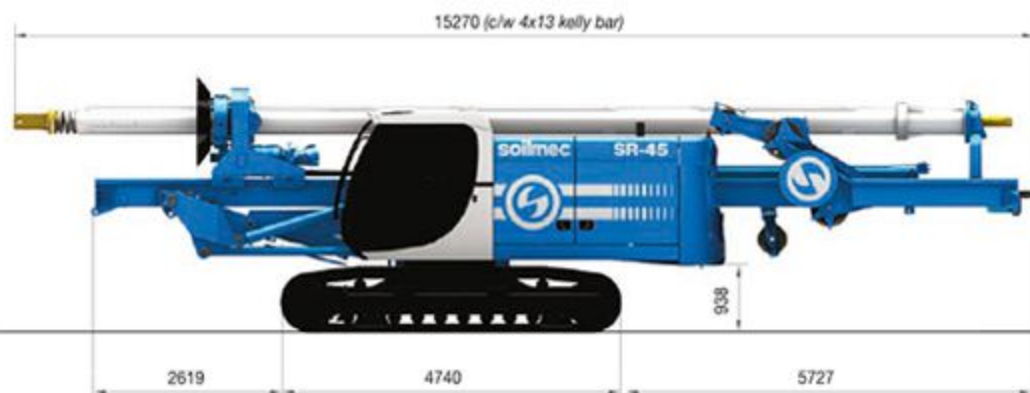
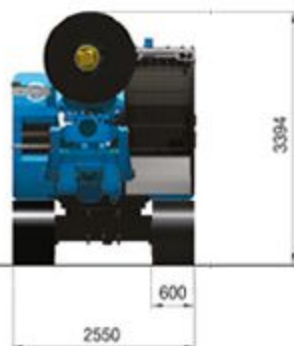

### Transport configuration

Width	2550 mm	100 in
Height	3400 mm	134 in
Length - Kelly <12 m	13050 mm	514 in
Weight - CCS Version c/w 4x9 Kelly bar	40600 kg	89507 lb
Weight - WCS Version c/w 4x9 Kelly bar	42100 kg	92814 lb

This brochure has been edited and distributed by SOILMEC Spa. The present document cancels and overrides any previous ones. This brochure shall not be distributed, reproduced or exhibited without SOILMEC Spa. authorization in accordance with to SOILMEC web site disclaimer condition.

SOILMEC Spa distributes machinery and structures all over the world, supported by SOILMEC Spa subsidiary companies and dealers. The complete Soilmec network list is available on the web site [www.soilmec.it](http://www.soilmec.it)